

## ▲ HYUNDAI CONSTRUCTION EQUIPMENT

### Head Office (Sales Office)

3F, BUNDANG FIRST TOWER, 55 BUNDANG-RO, BUNDANG-GU, SEONGNAM-SI,  
GYEONGGI-DO, 13591, KOREA

[www.hyundai-ce.com](http://www.hyundai-ce.com)

PLEASE CONTACT

2020. 05

MOVING YOU **FURTHER**

▲ **HYUNDAI**  
CONSTRUCTION EQUIPMENT

# HX300SL

With Tier 2 / Stage V Engine Installed

\*Photo may include optional equipment.



#### Gross Power

SAE J1995 / 250 HP (186 kW)  
at 2,200 rpm

#### Net Power

SAE J1349 / 245 HP (183 kW)  
at 2,200 rpm

#### Travel Speed

6.1 km/hr (3.8 mph) /  
3.4 km/hr (2.1 mph)

#### Operating Weight

30,200 kg / 66,580 lb

# WHAT'S NEWEST AND BEST

## Gross Power

SAE J1955 / 250 HP at 2,200 rpm

# 186 kW

## Net Power

SAE J1349 / 245 HP at 2,200 rpm

# 183 kW

## Travel Speed

3.8 mph

# 6.1 km/hr



## WORK MAX, WORTH MAX

- New Variable Power Control
- Fuel Rate Information **Option**
- IPC(Intelligent Power Control)
- Attachment Flow Control **Option**
- ECO Gauge
- New Cooling System with Increased Air Flow
- Enlarged Air Inlet with Grill Cover
- Cycle Time Improvement



## MORE RELIABLE, MORE SUSTAINABLE

- Durable Cooling Module
- Reinforced Pin, Bush, and Polymer Shim
- Reinforced Durability of Upper and Lower Structure and Attachments
- Wear Resistant Cover Plate
- Hi-grade (High-pressure) Hoses



## INFOTAINMENT FRONTIER

- New Front Side Air Conditioning Systems
- Intelligent and Wide Cluster
- New Air Conditioning System
- Wi-Fi Direct with Smart Phone (Miracast) **Option**
- Proportional Auxiliary Hydraulic System **Option**
- Quick Coupler Button **Option**
- New Audio System



## MODERN COMFORT, SIMPLE AND SAFE SOLUTION

- AAVM  
(Advanced Around View Monitoring)  
Camera System **Option**
- Hi-MATE  
(Remote Management System) **Option**
- Cab Suspension Mount
- Swing Lock System **Option**
- Fine Swing Control **Option**



\*Photo may include optional equipment.

**More fuel-efficiency**  
(Compared to 9S Series)

Leveling **12%** ↑

**More fuel-efficiency**  
(Compared to 9S Series)

Truck loading **10%** ↑

Faster leveling **2%** ↑

## OPTIMAL PERFORMANCE WITH FUEL EFFICIENCY

The HX Series is equipped with eco-friendly, high-performance engines that meet the Tier 4 Final emission requirements.

### Eco Gauge

Eco gauge enables economic operation of machines. The gauge level and color displays engine torque and fuel efficiency level. On top of that, the status of fuel consumption such as average rate and the total amount of fuel consumed is displayed. Hourly and daily based fuel consumption can be checked in the detailed menu as well.



### New Cooling System with Increased Air Flow

With the three-layer stacked up cooling module improving air inflow, the HX Series provides excellent cooling performance by increasing heat dissipation.



### IPC (Intelligent Power Control)

The IPC controls power depending on work environments. Its mode can be selected and released on the monitor. On the excavation mode, pump flow can be easily controlled by a lever, reducing fuel consumption.

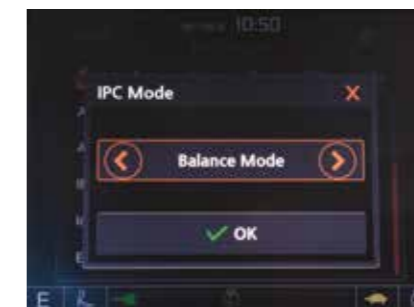

### Attachment Flow Control **Option**

The HX Series improves pump flow rate by independent control of two pumps. It optimizes attachments for effective flow rate setting depending on attachments (ten-breaker types and ten crusher types), enabling various operations matching the site environments.



### New Variable Power Control

The HX Series minimizes equipment input and output control signals to improve fuel efficiency. Its three-stage power mode ensures the highest performance in any operating environment.



\* **P(power) mode** : Maximizes speed and power of the equipment for heavy load work.



\* **S(standard) mode** : Optimizes performance and fuel efficiency of the equipment for general load work.



\* **E(economy) mode** : Improves the control system for light load work.

Photo may include optional equipment.

## ROBUST AND SAFE STRUCTURAL DESIGN

The true value of the HX Series lies in its durability and high productivity. The robust upper and lower frame structure can endure external shock and heavy work loads. Attachment performance has been proven through rigorous field testing. No matter how tough the working environment is, you can always rely on the HX series.

### Reinforced Pin, Bush, and Polymer Shim

The HX Series improves lubricity of connecting parts between the equipment and attachments. Gaps with attachments are minimized by wear-resistant long-life pins, bushes, and polymer shims, supporting the highest performance with invariable durability.

### Wear Resistant Cover Plate

A wear-resistant cover plate is installed at the end of the arm to minimize abrasion on the connector between the arm and the bucket. Vibration reduction of buckets enables more stable operation even in high-load work.



### Durable Cooling Module

The HX Series has a durable cooling module that passed stringent tests, demonstrating the highest productivity in tough working environments.



### Reinforced Durability of Upper and Lower Structure and Attachments

The upper and lower structure and attachments of the HX Series have higher durability than demanded on the site, as proven through numerous tests including road tests and virtual simulation. The wear resistance of the bucket has been improved by use of new material.



\*Photo may include optional equipment.

## ENHANCED INSTRUMENT PANEL FOR EASIER MONITORING

Many electronic functions are concentrated on the most convenient spot for operators to ensure work efficiency. The highly-advanced infotainment system, a product of HHI's intensive information technology, enables both productivity and pleasant work at the same time! The HX Series of HHI provides higher value and pleasure to customers.

### Intelligent and Wide Cluster

The 8-inch interactive touchscreen display of the HX Series is 15% larger than that of the previous model. The centralized switches on the display allow the operator to check the urea level and the temperature outside the cab.



### Wi-Fi Direct with Smart Phone (Miracast) **Option**

The smart terminal-miracast system uses the Wi-fi from the operator's smart phone to easily and conveniently enable features of the smart phone, such as navigating, surfing the web, watching videos, and listening to music, on the 8" screen. (Currently only available for Android phones.)



### New Air Conditioning System

Front side Air Vent holes make operators more convenient and fresh through direct air flow to driver's face, foot and body.



### Proportional Auxiliary Hydraulic System **Option**

- Proportional control switch for better speed control
- Enlarge the operation convenience



### New Front Side Air-conditioning System

The ventilation is designed for both warm and cool air reaching to operators' faces. It could help operators create more neat and enjoyable atmosphere through indoor air circulation.

\*Photo may include optional equipment.

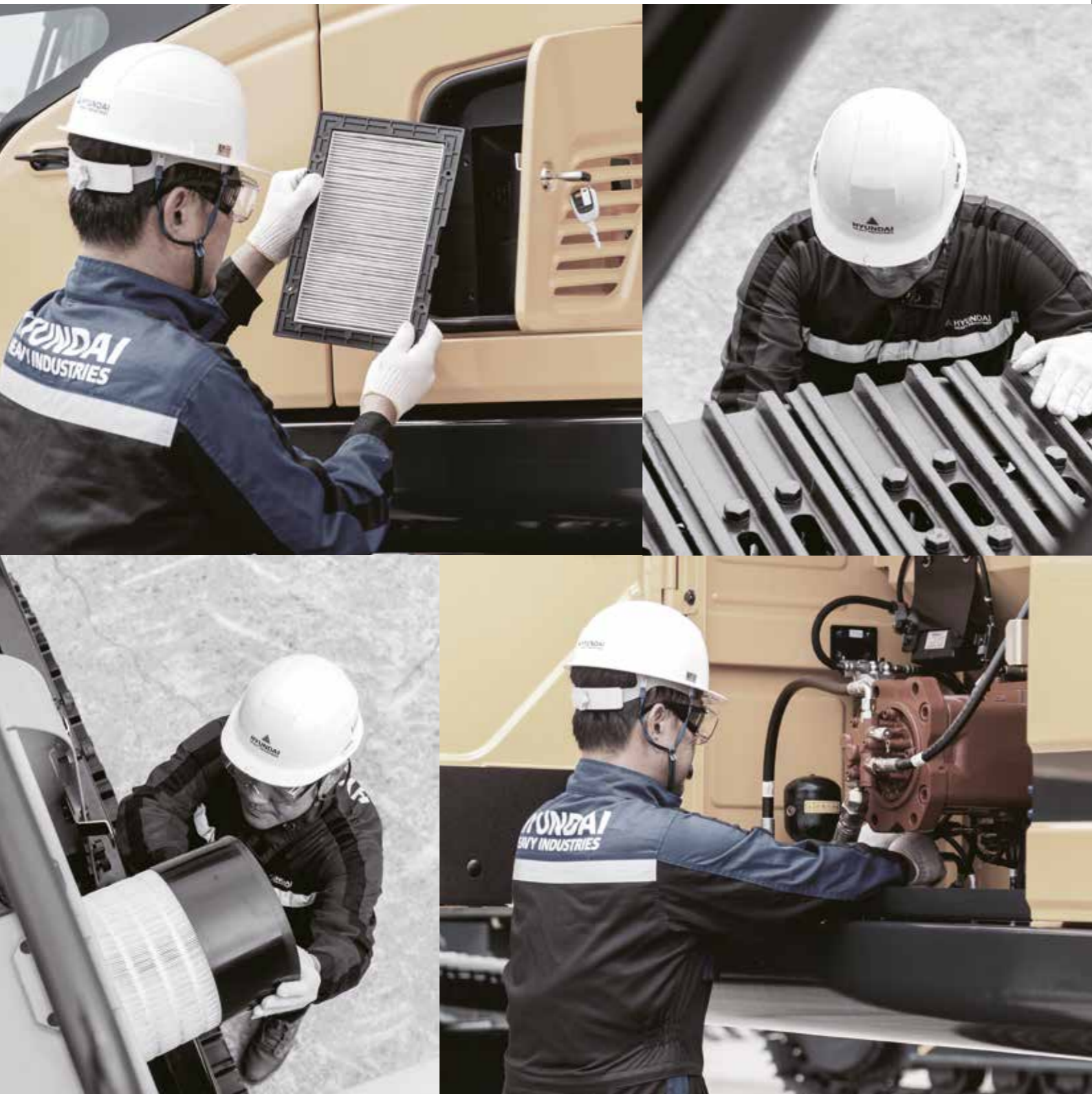

### Cab Suspension Mount

With a low-vibration design by the coil spring and damper inside the mount, the cab suspension mount of the HX Series reduces noise inside the cabin and improves durability, providing a comfortable operation space that lessens operators' fatigue.

### Swing Lock System Option

Swing lock system is provided to maintain stability when swing movement needs to be limited, improving operating speed and productivity.

### Fine Swing Control Option

Fine swing control is available for customer's convenience when users want to control fine swing.

## NEW EXTERIOR DESIGN FOR ROBUSTNESS AND SAFETY

The true value of the HX Series lies in its durability. The robust frame structure and the attachments show the real value of the HX Series in tough working environments and promise higher productivity.

The HX Series has a state-of-the-art AAVM video camera system to secure field of vision for operators in all directions, thereby preventing accidents. Operators can easily check the workplace in the front and rear and to the right and left.

\*AVM (Around View Monitoring) : Secure field of vision in all directions by nine views including 3D bird's eye view and 2D/4CH view.

\*IMOD (Intelligent Moving Object Detection) : Inform when people or dangerous objects are detected within the range of operation (Recognition distance : 5 m).



## HiMATE

### It's Convenient, Easy and Valuable

Hi-MATE Hyundai's newly developed remote management system, utilizes GPS-satellite technology to provide customers with the highest level of service and product support available. Hi-MATE enables users to remotely evaluate machine performance, access diagnostic information, and verify machine locations at the touch of a button.

### What is benefits



#### Increase Productivity

It helps you operate machines in efficient. You can check the difference between total engine hours and actual working hours. See how productive your machines are and plan any required cost saving solutions. Hi MATE offers working information such as working / idling hours, fuel consumption and rate.



#### Convenient and Easy Monitoring

There is nothing much to do to monitor your machines. Just log on to the Hi MATE website or mobile application. Hi MATE allows you to watch your machines whenever and wherever you are.



#### Security

Protect your machines from theft or unauthorized usage with Hi MATE. If the machine moves out of the Geo-fence boundary, you will get alerts.

# ADDITIONAL OPTIONS

## Fuel Rate Information Option



## Enlarged Air Inlet with Grill Cover

Enlarged vent hole of the air inlet side cover and fine net grill to prevent penetration of foreign materials further improve durability.



## Cycle Time Improvement

The HX Series provides higher productivity on the site by faster operation: it loads trucks up to 1 % faster and levels up to 2 % faster than the 9S Series.

## Hi-grade (High-pressure) Hoses

The HX Series uses high-pressure hoses with improved heat and pressure resistance, greatly increasing the durability of the equipment.



### Front Side Air-Vent

### Quick Coupler Button Option

Easy attachment replacement of equipment is available with quick coupler button.

### New Audio System

The radio player with a USB-based MP3 player, an integrated Bluetooth hands-free feature, and a built-in microphone allow for phone calls while at work and in transit. The radio player is conveniently located on the right side of the operator to allow for improved access.

# SPECIFICATIONS

## ENGINE

Maker / Model	HYUNDAI HM8.3		
Type	Water cooled, 4 cycle diesel, 6-cylinders in line, direct injection, turbocharged, charger air cooled, low emission		
Rated flywheel horse power	SAE J1995 (gross)	250 HP (186 kW) at 2,200 rpm	
	J1349 (net)	245 HP (183 kW) at 2,200 rpm	
DIN 6271 / 1 (gross)	253 PS (186 kW) at 2,200 rpm		
	DIN 6271 / 1 (net)	248 PS (186 kW) at 2,200 rpm	
Max. Power	265 HP (198 kW) at 2,000 rpm		
Max. torque	124 kgf·m (899 lbf·ft) at 1,300 rpm		
Bore × Stroke	114 × 135 mm (4.49" × 5.31")		
Piston displacement	8,290 cc (506 cu in)		
Batteries	2 × 12 V × 150 Ah		
Starting motor	24 V × 7.2 kW		
Alternator	24 V × 90 A		

## HYDRAULIC SYSTEM

### MAIN PUMP

Type	Variable displacement tandem axis piston pumps
Max. flow	2 × 285 l/min
Sub-pump for pilot circuit	Gear pump

Cross-sensing and fuel saving pump system.

### HYDRAULIC MOTORS

Travel	Two speed axial pistons motor with brake valve and parking brake
Swing	Axial piston motor with automatic brake

### RELIEF VALVE SETTING

Implement circuits	350 kgf/cm <sup>2</sup> (4,980 psi)
Travel	350 kgf/cm <sup>2</sup> (4,980 psi)
Power boost (boom, arm, bucket)	380 kgf/cm <sup>2</sup> (5,400 psi)
Swing circuit	300 kgf/cm <sup>2</sup> (4,270 psi)
Pilot circuit	40 kgf/cm <sup>2</sup> (570 psi)
Service valve	Installed

### HYDRAULIC CYLINDERS

No. of cylinder bore × stroke	Boom : 2-D140 × 1465mm
	Arm : 1-D150 × 1765mm
	Bucket : 1-D135 × 1185mm

## DRIVES & BRAKES

Drive method	Fully hydrostatic type
Drive motor	Axial piston motor, in-shoe design
Reduction system	Planetary reduction gear
Max. drawbar pull	27,400 kgf (60,410 lbf)
Max. travel speed (high / low)	6.1 km/hr (3.8 mph) / 3.4 km/hr (2.1 mph)
Gradeability	35° (70%)
Parking brake	Multi wet disc

## CONTROL

Pilot pressure operated joysticks and pedals with detachable lever provide almost effortless and fatigueless operation.

Pilot control	Two joysticks with one safety lever (LH) : Swing and arm, (RH) : Boom and bucket (ISO)
Traveling and steering	Two levers with pedals
Engine throttle	Electric, dial type

## SWING SYSTEM

Swing motor	Fixed displacement axial piston motor
Swing reduction	Planetary gear reduction
Swing bearing lubrication	Grease-bathed
Swing brake	Multi wet disc
Swing speed	12.2 rpm

## COOLANT & LUBRICANT CAPACITY

	liter	US gal	UK gal
Fuel tank	500	132.1	110.0
Engine coolant	25	6.6	5.5
Engine oil	26.5	7.0	5.8
Swing device	11	2.91	2.42
Final drive (each)	(8.0) 7.8	2.06	1.72
Hydraulic system (including tank)	330	87.2	72.6
Hydraulic tank	190	50.2	41.8

## UNDERCARRIAGE

The X-leg type center frame is integrally welded with reinforced box-section track frames. The undercarriage includes lubricated rollers, idlers, track adjusters with shock absorbing springs and sprockets, and a track chain with double or triple grouser shoes.

Center frame	X - leg type
Track frame	Pentagonal box type
No. of shoes on each side	48 EA
No. of carrier roller on each side	2 EA
No. of track roller on each side	9 EA
No. of rail guard on each side	2 EA

## OPERATING WEIGHT (APPROXIMATE)

Operating weight, including 6,250 mm (20' 6") boom, 3,050 mm (10' 0") arm, SAE heaped 1.27 m<sup>3</sup> (1.66 yd<sup>3</sup>) bucket, lubricant, coolant, full fuel tank, full hydraulic tank, and all standard equipments.

## OPERATING WEIGHT

Type	Width mm (in)	Operating weight		Ground pressure kgf/cm <sup>2</sup> (psi)
		kg (lb)		
Triple grouser	600 (24")	HX300S L	30,200 (66,580)	0.58 (8.27)
		HX300S HW	32,490 (71,630)	0.63 (8.89)
	700 (28")	HX300S L	30,770 (67,840)	0.51 (7.22)
		HX300S HW	33,060 (72,880)	0.55 (7.76)
800 (32")	HX300S L	31,150 (68,670)	0.45 (6.40)	
	HX300S LR	33,910 (74,760)	0.49 (6.96)	
Double grouser	700 (28")	HX300S HW	33,440 (73,720)	0.48 (6.87)
		HX300S HW	34,000 (74,960)	0.56 (7.96)

## AIR CONDITIONING SYSTEM

The air condition system for the machine contains the fluorinated greenhouse gas with global warming potential of R134a. (Global Warming Potential : 1,430) The system hold 0.8 kg refrigerant consisting of a CO<sub>2</sub> equivalent 1.14 kg metric tonne. For more information, Please refer to the manual.

# BUCKET SELECTION GUIDE & DIGGING FORCE

## HX300S L DIMENSIONS

6.25 m (20' 6"), 10.2 m (33' 6") BOOM and 2.1 m (6' 11"), 2.5 m (8' 2"), 3.05 m (10' 0"), 3.75 m (12' 4"), 7.85m (25' 9") ARM

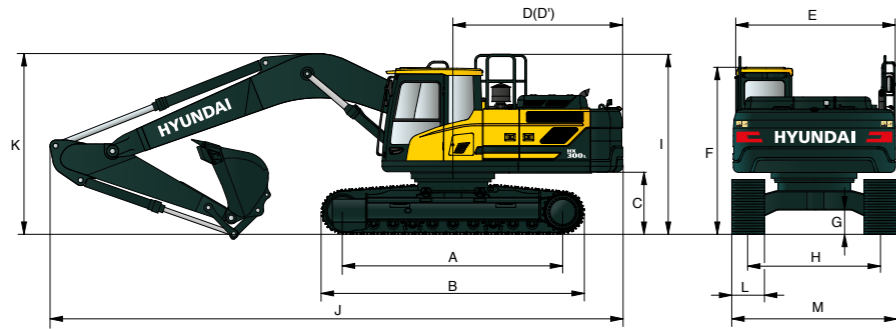

Unit : mm (ft-in)

A	Tumbler distance	4,030 (13' 3")
B	Overall length of crawler	4,940 (16' 2")
C	Ground clearance of counterweight	1,185 (3' 9")
D	Tail swing radius	3,345 (11' 0")
D'	Rear-end length	3,265 (10' 9")
E	Overall width of upperstructure	2,980 (9' 9")
F	Overall height of cab	3,130 (10' 3")
G	Min. ground clearance	500 (1' 8")
H	Track gauge	2,600 (8' 6")
I	Overall height of guardrail (Opt)	3,336 (10' 11")

Boom length	6,250 (20' 6")					10,200 (33' 6")
Arm length	2,100 (6' 11")	2,500 (8' 2")	3,050 (10' 0")	3,750 (12' 4")	7,850 (25' 9")	
J Overall length	10,900 (35' 9")	10,850 (35' 7")	10,740 (35' 3")	10,810 (35' 6")	14,750 (48' 5")	
K Overall height of boom	3,720 (12' 2")	3,560 (11' 8")	3,320 (10' 11")	3,570 (11' 9")	3,560 (11' 8")	
L Track shoe Width	600 (24")	700 (28")	800 (32")			
M Overall Width	3,200 (10' 6")	3,300 (10' 10")	3,400 (11' 1")			

## HX300S L WORKING RANGE

Unit : mm (ft-in)

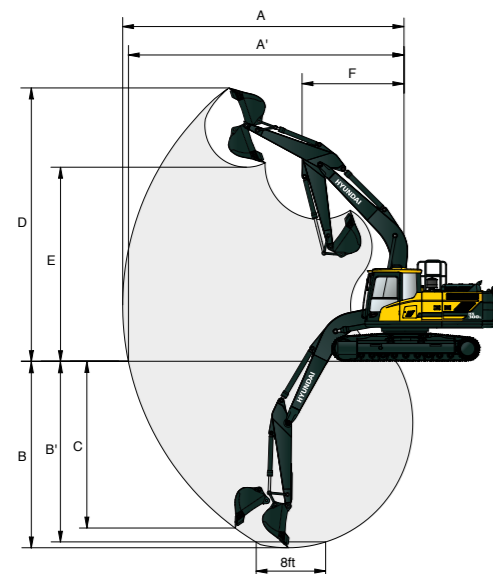

Boom length	6,250 (20' 6")					10,200 (33' 6")
Arm length	2,100 (6' 11")	2,500 (8' 2")	3,050 (10' 0")	3,750 (12' 4")	7,850 (25' 9")	
A Max. digging reach	10,040 (32' 11")	10,310 (33' 10")	10,810 (35' 6")	11,420 (37' 6")	18,530 (60' 10")	
A' Max. digging reach on ground	9,820 (32' 3")	10,100 (33' 2")	10,610 (34' 10")	11,230 (36' 10")	18,410 (60' 5")	
B Max. digging depth	6,380 (20' 11")	6,780 (22' 3")	7,330 (24' 1")	8,030 (26' 4")	14,740 (48' 4")	
B' Max. digging depth (8' level)	6,180 (20' 3")	6,600 (21' 8")	7,170 (23' 6")	7,890 (25' 11")	14,660 (48' 1")	
C Max. vertical wall digging depth	5,910 (19' 5")	5,760 (18' 11")	6,280 (20' 7")	6,990 (22' 11")	13,700 (44' 11")	
D Max. digging height	10,130 (33' 3")	9,980 (32' 9")	10,200 (33' 6")	10,410 (34' 2")	14,590 (47' 10")	
E Max. dumping height	6,990 (22' 11")	6,930 (22' 9")	7,150 (23' 5")	7,360 (24' 2")	12,270 (40' 3")	
F Min. swing radius	4,420 (14' 6")	4,320 (14' 2")	4,270 (14' 0")	4,220 (13' 10")	6,270 (20' 7")	

# BUCKET SELECTION GUIDE & DIGGING FORCE

## HX300S HW DIMENSIONS

6.25 m (20' 6") BOOM and 2.1 m (6' 11"), 2.5 m (8' 2"), 3.05 m (10' 0"), 3.75 m (12' 4") ARM

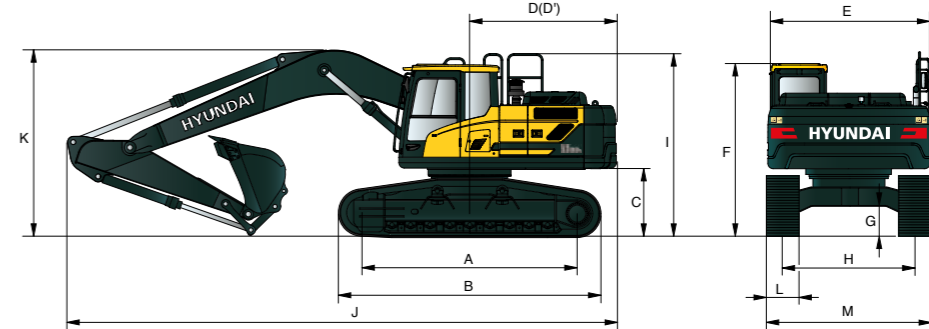

Unit : mm (ft-in)

A	Tumbler distance	4,030 (13' 3")
B	Overall length of crawler	5,010 (16' 5")
C	Ground clearance of counterweight	1,490 (4' 11")
D	Tail swing radius	3,345 (11' 0")
D'	Rear-end length	3,265 (10' 9")
E	Overall width of upperstructure	2,980 (9' 9")
F	Overall height of cab	3,435 (11' 3")
G	Min. ground clearance	765 (2' 6")
H	Track gauge	2,870 (9' 5")
I	Overall height of guardrail	3,650 (12' 0")

Boom length	6,250 (20' 6")			
Arm length	2,100 (6' 11")	2,500 (8' 2")	3,050 (10' 0")	3,750 (12' 4")
J Overall length	10,870 (35' 8")	10,780 (35' 4")	10,590 (34' 9")	10,670 (35' 0")
K Overall height of boom	3,830 (12' 7")	3,660 (12' 0")	3,440 (11' 3")	3,540 (11' 7")
L Track shoe Width	600 (24")	700 (28")	800 (32")	
M Overall Width	3,470 (11' 5")	3,570 (11' 9")	3,670 (12' 0")	

## HX300S HW WORKING RANGE

Unit : mm (ft-in)

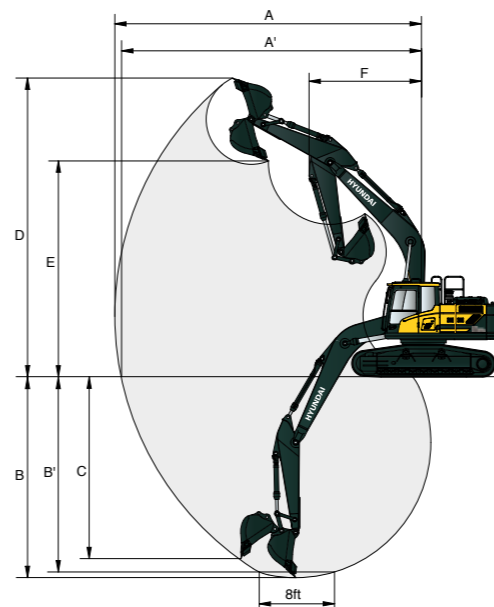

Boom length	6,250 (20' 6")			
Arm length	2,100 (6' 11")	2,500 (8' 2")	3,050 (10' 0")	3,750 (12' 4")
A Max. digging reach	10,040 (32' 11")	10,310 (33' 10")	10,810 (35' 6")	11,420 (37' 6")
A' Max. digging reach on ground	9,750 (32' 0")	10,020 (32' 10")	10,540 (34' 7")	11,170 (36' 8")
B Max. digging depth	6,060 (19' 11")	6,460 (21' 2")	7,010 (23' 0")	7,710 (25' 4")
B' Max. digging depth (8' level)	5,860 (19' 3")	6,280 (20' 7")	6,850 (22' 6")	7,570 (24' 10")
C Max. vertical wall digging depth	5,590 (18' 4")	5,440 (17' 10")	5,960 (19' 7")	6,670 (21' 11")
D Max. digging height	10,450 (34' 3")	10,300 (33' 10")	10,520 (34' 6")	10,730 (35' 2")
E Max. dumping height	7,320 (24' 0")	7,250 (23' 9")	7,470 (24' 6")	7,680 (25' 2")
F Min. swing radius	4,420 (14' 6")	4,320 (14' 2")	4,270 (14' 0")	4,220 (13' 10")

# BUCKET SELECTION GUIDE & DIGGING FORCE

## BUCKETS

All buckets are welded with high-strength steel.



SAE heaped m <sup>3</sup> (yd <sup>3</sup> )	1.27 (1.66)	◆ 1.27 (1.66)	◆ 1.16 (1.52)	◆ 1.33 (1.74)	★ 0.52 (0.68)
	1.50 (1.96)	◆ 1.46 (1.91)	◆ 1.49 (1.95)		
	1.73 (2.26)				
	1.85 (2.42)				

Capacity m <sup>3</sup> (yd <sup>3</sup> )		Width mm (in)	Weight kg (lb)	Tooth EA	Recommendation mm (ft-in)				
SAE heaped	CECE heaped	Without side cutters			6,250 (20' 6") Boom				10,200 (33' 6") Boom
					2,100 (6' 11") Arm	2,500 (8' 2") Arm	3,050 (10' 0") Arm	3,750 (12' 4") Arm	7,850 (25' 9") Arm
★0.52 (0.68)	0.45 (0.59)	935 (36.8")	460 (1,010)	5	-	-	-	-	●
1.27 (1.66)	1.10 (1.44)	1,290 (50.8")	1,010 (2,230)	5	●	●	●	●	-
1.50 (1.96)	1.30 (1.7)	1,490 (58.7")	1,080 (2,380)	5	●	●	●	■	-
1.73 (2.26)	1.50 (1.96)	1,700 (66.9")	1,170 (2,580)	6	●	■	●	▲	-
1.85 (2.42)	1.60 (2.09)	1,800 (70.9")	1,230 (2,710)	6	■	■	●	▲	-
◆ 1.27 (1.66)	1.10 (1.44)	1,310 (51.6")	1,240 (2,730)	5	●	●	●	■	-
◆ 1.46 (1.91)	1.28 (1.67)	1,460 (57.5")	1,320 (2,910)	5	●	●	●	■	-
◆ 1.16 (1.52)	1.00 (1.31)	1,340 (52.8")	1,280 (2,820)	5	●	●	●	-	-
◆ 1.33 (1.74)	1.16 (1.52)	1,420 (55.9")	1,440 (3,170)	5	●	●	●	-	-
◆ 1.49 (1.95)	1.28 (1.67)	1,620 (63.8")	1,440 (3,170)	5	●	●	●	-	-

- ◆ Heavy duty bucket
- ◆ Rock-Heavy duty bucket
- ★ Long reach bucket
- : Applicable for materials with density of 2,100 kgf/m<sup>3</sup> (3,500 lbf/yd<sup>3</sup>) or less
- : Applicable for materials with density of 1,800 kgf/m<sup>3</sup> (3,000 lbf/yd<sup>3</sup>) or less
- : Applicable for materials with density of 1,500 kgf/m<sup>3</sup> (2,500 lbf/yd<sup>3</sup>) or less
- ▲ : Applicable for materials with density of 1,200 kgf/m<sup>3</sup> (2,000 lbf/yd<sup>3</sup>) or less



## ATTACHMENT

Booms and arms are of all-welded, low-stress, full-box section design.  
 6,250 mm (20' 6"), 10,200 mm (33' 6") Booms and  
 2,100 mm (6' 11"), 2,500 mm (8' 2"), 3,050mm (10' 0"), 3,750mm (12' 4"),  
 7,850 mm (25' 9") Arms are available, Hyundai Bucket are all-welded,  
 high-strength steel implements.

## DIGGING FORCE

Boom	Length	mm (ft-in)	6,250 (20' 6")					10,200 (33' 6")	Remark
	Weight	kg (lb)	2,780 (6,130)					3,530 (7,780)	
Arm	Length	mm (ft-in)	2,100 (6' 11")	2,500 (8' 2")	3,050 (10' 0")	3,750 (12' 4")	7,850 (25' 9")	Remark	
	Weight	kg (lb)	1,345 (2,970)	1,430 (3,150)	1,545 (3,410)	1,675 (3,690)	1,685 (3,710)		
Bucket Digging Force	kN	164.8 [179.8]	165.7 [180.8]	165.7 [180.8]	166.7 [181.9]	70.6			
	SAE kgf	16,800 [18,330]	16,900 [18,440]	16,900 [18,440]	17,000 [18,550]	7,200			
	lbf	37,040 [40,410]	37,260 [40,650]	37,260 [40,650]	37,480 [40,900]	15,870			
ISO	kN	191.2 [208.6]	191.2 [208.6]	192.2 [209.7]	192.2 [209.7]	82.4			
	kgf	19,500 [21,270]	19,500 [21,270]	19,600 [21,380]	19,600 [21,380]	8,400			
	lbf	42,990 [46,890]	42,990 [46,890]	43,210 [47,130]	43,210 [47,130]	18,520			
Arm Crowd Force	kN	180.4 [196.8]	155.9 [170.1]	131.4 [143.4]	114.7 [125.1]	47.1			
	SAE kgf	18,400 [20,070]	15,900 [17,350]	13,400 [14,620]	11,700 [12,760]	4,800			
	lbf	40,570 [44,250]	35,050 [38,250]	29,540 [32,230]	25,790 [28,130]	10,580			
ISO	kN	190.3 [207.5]	163.8 [178.7]	136.3 [148.7]	119.6 [130.5]	48.1			
	kgf	19,400 [21,160]	16,700 [18,220]	13,900 [15,160]	12,200 [13,310]	4,900			
	lbf	42,770 [46,650]	36,820 [40,170]	30,640 [33,420]	26,900 [29,340]	10,800			

Note : Boom weight includes arm cylinder, piping, and pin  
 Arm weight includes bucket cylinder, linkage, and pin

# LIFTING CAPACITY

Rating over-front Rating over-side or 360 degree

## HX300S L

**6.25 m (20' 6") boom, 3.05 m (10' 0") arm equipped with 5,200 kg counter weight and 600 mm (24") triple grouser shoe.**

Load point height m (ft)		Load radius										At max. reach		
		3.0m (9.8 ft)		4.5m (14.8 ft)		6.0m (19.7 ft)		7.5m (24.6 ft)		9.0m (29.5 ft)		Capacity		Reach
														m (ft)
7.5 m (24.6 ft)	kg											*4,410	*4,410	7.38
	lb											*9,720	*9,720	(24.2)
6.0 m (19.7 ft)	kg						*6,490	5,710				*4,220	*4,220	8.30
	lb						*14,310	12,590				*9,300	*9,300	(27.2)
4.5 m (14.8 ft)	kg			*9,450	*9,450	*7,760	*7,760	*6,980	5,540			*4,210	4,200	8.86
	lb			*20,830	*20,830	*17,110	*17,110	*15,390	12,210			*9,280	9,260	(29.1)
3.0 m (9.8 ft)	kg			*12,510	11,250	*9,210	7,400	*7,720	5,320	*5,490	4,000	*4,340	3,900	9.14
	lb			*27,580	24,800	*20,300	16,310	*17,020	11,730	*12,100	8,820	*9,570	8,600	(30.0)
1.5 m (4.9 ft)	kg			*14,900	10,490	*10,550	7,000	8,210	5,110	*6,190	3,900	*4,640	3,790	9.17
	lb			*32,850	23,130	*23,260	15,430	18,100	11,270	*13,650	8,600	*10,230	8,360	(30.1)
Ground Line	kg			*15,940	10,170	11,280	6,740	8,040	4,950			*5,160	3,870	8.94
	lb			*35,140	22,420	24,870	14,860	17,730	10,910			*11,380	8,530	(29.3)
-1.5 m (-4.9 ft)	kg	*11,100	*11,100	*15,950	10,110	11,160	6,640	7,970	4,890			*6,050	4,180	8.44
	lb	*24,470	*24,470	*35,160	22,290	24,600	14,640	17,570	10,780			*13,340	9,220	(27.7)
-3.0 m (-9.8 ft)	kg	*17,910	*17,910	*15,100	10,220	11,210	6,690	8,050	4,960			*7,770	4,870	7.61
	lb	*39,480	*39,480	*33,290	22,530	24,710	14,750	17,750	10,930			*17,130	10,740	(25.0)
-4.5 m (-14.8 ft)	kg	*18,100	*18,100	*13,040	10,520	*9,550	6,920					*8,810	6,480	6.32
	lb	*39,900	*39,900	*28,750	23,190	*21,050	15,260					*19,420	14,290	(20.7)
-6.0 m (-19.7 ft)	kg													
	lb													

**6.25 m (20' 6") boom, 2.10 m (6' 11") arm equipped with 5,200 kg counter weight and 600 mm (24") triple grouser shoe.**

Load point height m (ft)		Load radius										At max. reach		
		3.0 m (9.8 ft)		4.5 m (14.8 ft)		6.0 m (19.7 ft)		7.5 m (24.6 ft)		Capacity		Reach		
												m (ft)		
7.5 m (24.6 ft)	kg					*7,670	*7,670			*7,890	7,270	6.40		
	lb					*16,910	*16,910			*17,390	16,030	(21.0)		
6.0 m (19.7 ft)	kg					*7,900	*7,900			*7,790	5,630	7.44		
	lb					*17,420	*17,420			*17,170	12,410	(24.4)		
4.5 m (14.8 ft)	kg					*8,950	7,670	*7,930	5,470	7,630	4,850	8.06		
	lb					*19,730	16,910	*17,480	12,060	16,820	10,690	(26.5)		
3.0 m (9.8 ft)	kg					*10,270	7,270	8,410	5,290	7,090	4,480	8.37		
	lb					*22,640	16,030	18,540	11,660	15,630	9,880	(27.5)		
1.5 m (4.9 ft)	kg					*11,350	6,960	8,220	5,130	6,960	4,380	8.40		
	lb					*25,020	15,340	18,120	11,310	15,340	9,660	(27.6)		
Ground Line	kg					11,330	6,810	8,120	5,040	7,220	4,520	8.16		
	lb					24,980	15,010	17,900	11,110	15,920	9,960	(26.8)		
-1.5 m (-4.9 ft)	kg			*15,530	10,360	11,310	6,800	8,160	5,070	8,020	4,990	7.60		
	lb			*34,240	22,840	24,930	14,990	17,990	11,180	17,680	11,000	(24.9)		
-3.0 m (-9.8 ft)	kg	*18,440	*18,440	*14,030	10,560	*10,600	6,940			*9,060	6,090	6.66		
	lb	*40,650	*40,650	*30,930	23,280	*23,370	15,300			*19,970	13,430	(21.9)		
-4.5 m (-14.8 ft)	kg			*10,580	*10,580					*8,760	*8,760	5.12		
	lb			*23,320	*23,320					*19,310	*19,310	(16.8)		

1 | 1 | Lifting capacity are based on ISO 10567. | 2 | Lifting capacity of the Robex Series does not exceed 75% of tipping load with the machine on firm, level ground or 87% of full hydraulic capacity. | 3 | The Lift-point is bucket pivot mounting pin on the arm (without bucket mass). | 4 | (\*) indicates load limited by hydraulic capacity.

# LIFTING CAPACITY

Rating over-front Rating over-side or 360 degree

## HX300S L

**6.25 m (20' 6") boom, 2.50 m (8' 2") arm equipped with 5,200 kg counter weight and 600 mm (24") triple grouser shoe.**

Load point height m (ft)		Load radius										At max. reach		
		3.0 m (9.8 ft)		4.5 m (14.8 ft)		6.0 m (19.7 ft)		7.5 m (24.6 ft)		Capacity		Reach		
												m (ft)		
7.5 m (24.6 ft)	kg											*6,980	*6,980	6.74
	lb											*15,390	*15,390	(22.1)
6.0 m (19.7 ft)	kg											*7,380	*7,380	7.74
	lb											*16,270	*16,270	(25.4)
4.5 m (14.8 ft)	kg					*10,660	*10,660	*8,470	7,750	*7,530	5,500	*6,420	4,620	8.34
	lb					*23,500	*23,500	*18,670	17,090	*16,600	12,130	*14,150	10,190	(27.4)
3.0 m (9.8 ft)	kg					*13,720	10,980	*9,850	7,320	*8,180	5,300	*6,640	4,270	8.64
	lb					*30,250	24,210	*21,720	16,140	*18,030	11,680	*14,640	9,410	(28.3)
1.5 m (4.9 ft)	kg							*11,040	6,970	8,220	5,120	6,630	4,160	8.67
	lb							*24,340	15,370	18,120	11,290	14,620	9,170	(28.4)
Ground Line	kg					*16,170	10,220	11,300	6,770	8,080	5,000	6,840	4,270	8.43
	lb					*35,650	22,530	24,910	14,930	17,810	11,020	15,080	9,410	(27.7)
-1.5 m (-4.9 ft)	kg	*11,150	*11,150	*15,780	10,240	11,240	6,730	8,060	4,980	7,520	4,670	7.89		
	lb	*24,580	*24,580	*34,790	22,580	24,780	14,840	17,770	10,980	16,580	10,300	(25.9)		
-3.0 m (-9.8 ft)	kg	*19,830	*19,830	*14,550	10,410	*10,980	6,830			*9,000	5,590	6.99		
	lb	*43,720	*43,720	*32,080	22,950	*24,210	15,060			*19,840	12,320	(22.9)		
-4.5 m (-14.8 ft)	kg	*15,970	*15,970	*11,820	10,790					*9,210	7,980	5.55		
	lb	*35,210	*35,210	*26,060	23,790					*20,300	17,590	(18.2)		

**6.25 m (20' 6") boom, 3.75 m (12' 4") arm equipped with 5,200 kg counter weight and 600 mm (24") triple grouser shoe.**

Load point height m (ft)		Load radius										At max. reach								
		1.5 m (4.9 ft)		3.0 m (9.8 ft)		4.5 m (14.8 ft)		6.0 m (19.7 ft)		7.5 m (24.6 ft)		9.0 m (29.5 ft)		Capacity		Reach				
																m (ft)				
9.0 m (29.5 ft)	kg													*3,820	*3,820	6.87				
	lb													*8,420	*8,420	(22.6)				
7.5 m (24.6 ft)	kg													*3,490	*3,490	8.14				
	lb													*7,690	*7,690	(26.7)				
6.0 m (19.7 ft)	kg													*5,700	*5,700	8.97				
	lb													*12,570	*12,570	(29.4)				
4.5 m (14.8 ft)	kg									*6,830	*6,830	*6,290	5,620	*5,230	4,140	*3,370	*3,370	9.50		
	lb									*15,060	*15,060	*13,870	12,390	*11,530	9,130	*7,430	*7,430	(31.2)		
3.0 m (9.8 ft)	kg									*10,960	*10,960	*8,340	7,530	*7,110	5,370	6,370	4,020	*3,490	*3,490	9.76
	lb									*24,160	*24,160	*18,390	16,600	*15,670	11,840	14,040	8,860	*7,690	*7,690	(32.0)
1.5 m (4.9 ft)	kg									*13,740	10,700	*9,850	7,070	*7,970	5,120	6,230	3,890	*3,720	3,400	9.79
	lb									*30,290	23,590	*21,720	15,590	*17,570	11,290	13,730	8,580	*8,200	7,500	(32.1)
Ground Line	kg									*15,380	10,180	*10,980	6,740	8,020	4,920	6,110	3,780	*4,110	3,450	9.58
	lb									*33,910	22,440	*24,210	14,860	17,680	10,850	13,470	8,330	*9,060	7,610	(31.4)
-1.5 m (-4.9 ft)	kg	*7,070	*7,070	*10,570	*10,570	*15,920	10,000	11,090	6,570	7,890	4,810	*5,710	3,740	*4,750	3,680	9.11				
	lb	*15,590	*15,590	*23,300	*23,300	*35,100	22,050	24,450	14,480	17,390	10,600	*12,590	8,250	*10,470	8,110	(29.9)				
-3.0 m (-9.8 ft)	kg	*11,090	*11,090	*15,460	*15,460	*15,540	10,020	11,060	6,540	7,890	4,800			*5,900	4,180	8.35				
	lb	*24,450	*24,450	*34,080	*34,080	*34,260	22,090	24,380	14,420	17,390	10,580			*13,010	9,220	(27.4)				
-4.5 m (-14.8 ft)	kg	*15,990	*15,990	*20,280	*20,280	*14,140	10,230	*10,510	6,680					*8,250	5,240	7.19				
	lb	*35,250	*35,250	*44,710	*44,710	*31,170	22,550	*23,170	14,730					*18,190	11,550	(23.6)				
-6.0 m (-19.7 ft)	kg					*15,400	*15,400	*10,850	10,700					*8,670	8,240	5.38				
	lb																			

# LIFTING CAPACITY

Rating over-front Rating over-side or 360 degree

HX300S HW													
6.25 m (20' 6") boom, 3.05 m (10' 0") arm equipped with 5,200 kg counter weight and 600 mm (24") triple grouser shoe.													
Load point height m (ft)		Load radius										At max. reach	
		3.0 m (9.8 ft)		4.5 m (14.8 ft)		6.0 m (19.7 ft)		7.5 m (24.6 ft)		9.0 m (29.5 ft)		Capacity	Reach
													m (ft)
9.0 m (29.5 ft)	kg											*4,760	6.34
	lb											*10,490	(20.8)
7.5 m (24.6 ft)	kg						*5,020	*5,020				*4,340	7.63
	lb						*11,070	*11,070				*9,570	(25.0)
6.0 m (19.7 ft)	kg					*6,840	*6,840	*6,560	*6,560			*4,200	8.45
	lb					*15,080	*15,080	*14,460	*14,460			*9,260	(27.7)
4.5 m (14.8 ft)	kg		*10,120	*10,120		*8,080	*8,080	*7,140	6,600			*4,230	8.95
	lb		*22,310	*22,310		*17,810	*17,810	*15,740	14,550			*9,330	(29.4)
3.0 m (9.8 ft)	kg		*13,160	*13,160	*9,540	8,830	*7,900	6,370	*5,780	4,830		*4,400	9.17
	lb		*29,010	*29,010	*21,030	19,470	*17,420	14,040	*12,740	10,650		*9,700	(30.1)
1.5 m (4.9 ft)	kg		*15,250	12,840	*10,800	8,440	*8,620	6,150	*6,100	4,730		*4,740	9.14
	lb		*33,620	28,310	*23,810	18,610	*19,000	13,560	*13,450	10,430		*10,450	(30.0)
Ground Line	kg	*6,560	*6,560	*16,020	12,580	*11,570	8,220	8,630	6,020			*5,320	8.86
	lb	*14,460	*14,460	*35,320	27,730	*25,510	18,120	19,030	13,270			*11,730	(29.1)
-1.5 m (-4.9 ft)	kg	*12,500	*12,500	*15,840	12,570	*11,710	8,150	8,590	5,980			*6,340	8.29
	lb	*27,560	*27,560	*34,920	27,710	*25,820	17,970	18,940	13,180			*13,980	(27.2)
-3.0 m (-9.8 ft)	kg	*19,800	*19,800	*14,760	12,720	*11,060	8,230					*8,390	7.36
	lb	*43,650	*43,650	*32,540	28,040	*24,380	18,140					*18,500	(24.2)
-4.5 m (-14.8 ft)	kg	*17,010	*17,010	*12,280	*12,280							*8,860	5.93
	lb	*37,500	*37,500	*27,070	*27,070							*19,530	(19.4)

HX300S LR																										
10.20 m (33' 6") boom, 78.5 m (25' 9") arm equipped with 7,000 kg counter weight and 800 mm (31") triple grouser shoe.																										
Load point height m (ft)		Load radius										At max reach														
		1.5 m (4.9 ft)		3.0 m (9.8 ft)		4.5 m (14.8 ft)		6.0 m (19.7 ft)		7.5 m (24.6 ft)		9.0 m (29.5 ft)		10.5 m (34.4 ft)		12.0 m (39.4 ft)		13.5 m (44.3 ft)		15.0 m (49.2 ft)		16.5 m (54.1 ft)		Capacity	Reach	
																									m (ft)	
135 m (443 ft)	kg																							*750	12.91	
	lb																								*1,650	(42.4)
120 m (394 ft)	kg																							*1,000	14.11	
	lb																							*2,200	(46.3)	
105 m (344 ft)	kg																							*1,300	15.06	
	lb																							*2,870	(49.4)	
90 m (295 ft)	kg																							*1,480	15.82	
	lb																							*3,260	(51.9)	
75 m (246 ft)	kg																							*1,650	16.40	
	lb																							*3,640	(53.8)	
60 m (197 ft)	kg																							*2,010	16.83	
	lb																							*4,430	(52.2)	
45 m (148 ft)	kg																							*2,570	17.11	
	lb																							*5,670	(56.1)	
30 m (98 ft)	kg																							*4,070	17.25	
	lb																							*17,750	(66.6)	
15 m (49 ft)	kg																							*4,070	17.27	
	lb																							*8,970	(66.7)	
Ground Line	kg																							*1,230	17.15	
	lb																							*2,710	(66.3)	
-15 m (-49 ft)	kg	*1,280	*1,280	*1,770	*1,770	*3,090	*3,090	*5,900	*5,900	*6,890	4,920	*5,520	3,870	*4,630	3,130	*4,010	2,570	*3,570	2,140	*2,610	1,790	*1,320	*1,320	*890	16.90	
	lb	*2,820	*2,820	*3,900	*3,900	*6,810	*6,810	*13,010	*13,010	*15,190	10,850	*12,170	8,530	*10,210	6,900	*8,840	5,670	*7,870	4,720	*5,750	3,950	*2,910	*2,910	*1,960	(55.4)	
-30 m (-98 ft)	kg	*1,920	*1,920	*2,410	*2,410	*3,550	*3,550	*5,840	*5,840	*7,330	4,700	*5,890	3,690	*4,920	2,980	*4,170	2,460	*3,520	2,060	*2,630	1,740	*1,000	*1,000	*1,000	16.50	
	lb	*4,230	*4,230	*5,310	*5,310	*7,830	*7,830	*12,870	*12,870	*16,160	10,360	*12,990	8,140	*10,850	6,570	*13,910	5,420	*19,190	4,540	*25,800	3,840	*2,200	*2,200	*2,200	(54.1)	
-45 m (-148 ft)	kg	*2,570	*2,570	*3,100	*3,100	*4,190	*4,190	*6,310	6,230	*7,600	4,580	6,110	3,570	4,930	2,890	4,090	2,390	3,470	2,010	*2,390	1,710			*1,140	15.96	
	lb	*5,670	*5,670	*6,830	*6,830	*9,240	*9,240	*13,910	13,730	*16,760	10,100	13,470	7,870	10,870	6,370	9,920	5,270	7,650	4,430	*5,270	3,770			*2,510	(52.3)	
-60 m (-197 ft)	kg	*3,270	*3,270	*3,860	*3,860	*5,000	*5,000	*7,130	6,220	*7,700	4,530	6,060	3,520	4,880	2,840	4,060	2,360	3,450	1,990	*1,720	1,710			*1,340	15.24	
	lb	*7,210	*7,210	*8,510	*8,510	*11,020	*11,020	*15,720	13,710	*16,980	9,990	13,360	7,760	10,760	6,260	8,950	5,200	7,610	4,390	*3,790	3,770			*2,950	(50.0)	
-75 m (-246 ft)	kg	*4,020	*4,020	*4,710	*4,710	*5,970	*5,970	*8,300	6,290	*7,620	4,560	6,070	3,530	4,890	2,850	4,070	2,360	*3,260	2,010					*1,630	14.33	
	lb	*8,860	*8,860	*10,380	*10,380	*13,160	*13,160	*18,300	13,870	*16,800	10,050	13,380	7,780	10,780	6,280	8,970	5,200	*7,190	4,430					*3,590	(47.0)	
-90 m (-295 ft)	kg	*4,850	*4,850	*5,690	*5,690	*7,170	*7,170	*9,220	6,440	*7,350	4,650	*6,040	3,600	4,950	2,900	4,130	2,420							*2,100	13.19	
	lb	*10,690	*10,690	*12,540	*12,540	*15,810	*15,810	*20,330	14,200	*16,200	10,250	*13,320	7,940	10,910	6,390	9,110	5,340							*4,630	(48.3)	
-105 m (-344 ft)	kg	*5,790	*5,790	*6,860	*6,860	*8,720	*8,720	*11,490	6,660	*6,820	4,810	*5,610	3,730	*4,650	3,020										*2,960	11.74
	lb	*12,760	*12,760	*15,120	*15,120	*19,220	*19,220	*24,160	14,680	*15,040	10,600	*12,370	8,220	*10,250	6,660										*6,530	(38.5)
-120 m (-394 ft)	kg																								*8,320	9.85
	lb																								*18,340	(32.3)
-135 m (-443 ft)	kg																									
	lb																									

1 | Lifting capacity are based on ISO 10567. | 2 | Lifting capacity of the Robex Series does not exceed 75% of tipping load with the machine on firm, level ground or 87% of full hydraulic capacity. | 3 | The Lift-point is bucket pivot mounting pin on the arm (without bucket mass). | 4 | (\*) indicates load limited by hydraulic capacity.

# STANDARD / OPTION

ENGINE	STD
Hyundai HM8.3 Engine	●
HYDRAULIC SYSTEM	STD
Intelligent Power Control (IPC)	
3-power mode, 2-work mode, user mode	●
Variable power control	●
Pump flow control	●
Attachment mode flow control	
Engine auto idle	●
Engine auto shutdown control	
CAB & INTERIOR	STD
ISO Standard Cabin	
Rise-up type windshield wiper	●
Radio / USB player	●
Handsfree mobile phone system with USB	●
12 V power outlet (24 V DC to 12 V DC converter)	●
Electric horn	●
All-weather steel cab with 360° visibility	●
Safety glass windows	●
Sliding fold-in front window	●
Sliding side window (LH)	●
Lockable door	●
Hot & Cool box	●
Storage compartment & Ashtray	●
Sun visor	●
Door and cab locks, one key	●
Pilot-operated slidable joystick	●
Cabin lights	●
Cabin front window rain guard	
Cabin roof-steel cover	●
Automatic Climate Control	
Air conditioner & Heater	●
Defroster	●
Starting aid (air grid heater) for cold weather	●
Centralized Monitoring	
8" LCD display - Normal type	●
8" LCD display - Premium type	
Engine speed or trip meter / Accel	●
Engine coolant temperature gauge	●
Max power	●
Low speed / High speed	●
Auto idle	●
Overload	●
Check engine	●
Air cleaner clogging	●
Indicators	●
ECO gauges	●
Fuel level gauge	●
Hyd. oil temperature gauge	●
Warnings	●
Communication error	●
Low battery	●
Clock	●
Seat	
Mechanical suspension without heater	●
Mechanical suspension with heater	
Adjustable air suspension without heater	
Adjustable air suspension with heater	
Cabin FOPS/FOG	
FOPS (Falling object protective structures)	
ISO 3449 Level 2	
FOG (Falling object guard)	Front & Tops guard
ISO/DIS 10262 Level 2	Top guard
Cabin ROPS	
ROPS (Roll over protective structures) - ISO 12117-2	

**MEMO**